

INTG6 Series • Performance @ Maximum Flow

Voltage	Flow (GPM)	Flow (L)	Ttl. Hd. (Ft)	Ttl. Hd. (PSI)	Ttl. Hd. (BAR)	Ttl. Hd. (M)
48vdc	15.00	56.8	25.33	10.98	0.76	7.72
24vdc	12.00	45.4	34.81	15.09	1.04	10.61

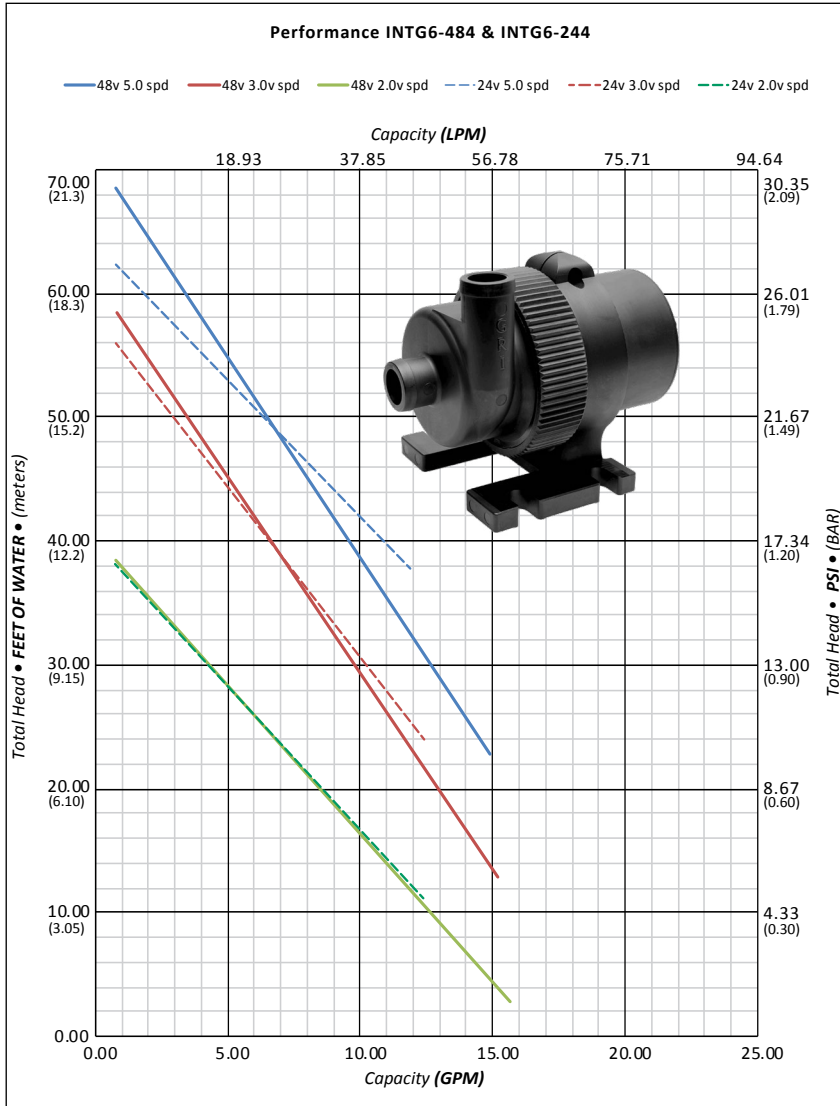

Note: Testing performed in a controlled laboratory environment. Actual performance may vary (+) or (-) 10% from the information shown.
Do Not Run Pumps Dry. Pumps must be in a continuous flooded suction environment.

Specifications

- Maximum System Pressure: 75 psi
- Approximate Weight (w/ external box): 4 lbs (1814.37 grams)
- Ports: 1" MHB

Materials In Contact With Solution

Body: PPS	Housing: PPS	Static O-Ring: EPDM, FKM (upon request)
Impeller: PPS	Pump Shaft: Ceramic	

Motor Specifications

Motor: Integrated, Brushless DC	Control Options
Supply Voltage: 12-24, 48 VDC	
Electronics Maximum Power: 200 Watts	<ul style="list-style-type: none"> Direct Supply Voltage: Speed of the pump determined by the voltage supplied Analog: 0-5v DC Signal Digital: PWM CAN-Bus: Option available Tachometer: Feedback option available
To protect the control board, each Integrity Series pump will be issued with a Maximum Power limit (Watts). To stay within this limit, the recommended fuse size (Amps) will be based on the voltage supplied. (Watts = Voltage X Amps)	

Maximum Fluid Temperature Rating Chart

Controller Position	Maximum Fluid Temp Rating
Separate from pump	221°F (105°C)
Within pump's housing	Not available
Various factors influence the recommended maximum temperature rating. These factors play a role in determining the pump's life and applied warranties. In some applications, a higher maximum fluid temperature rating may be warranted.	Factors influencing maximum temperature rating include, but are not limited to: <ul style="list-style-type: none"> Starting temperature of fluid in system Ambient temperature Required performance, application's specifications Run time

Optional Agency Approvals

Contact GRI

RoHS/REACH

Many GRI pumps are RoHS & REACH compliant. For declarations by specific model numbers, please contact GRI.

IP (Ingress Protection)

IP68: No ingress of dust, protection against continuous water immersion.*
 * Upon request only. Minimum quantities may be required.

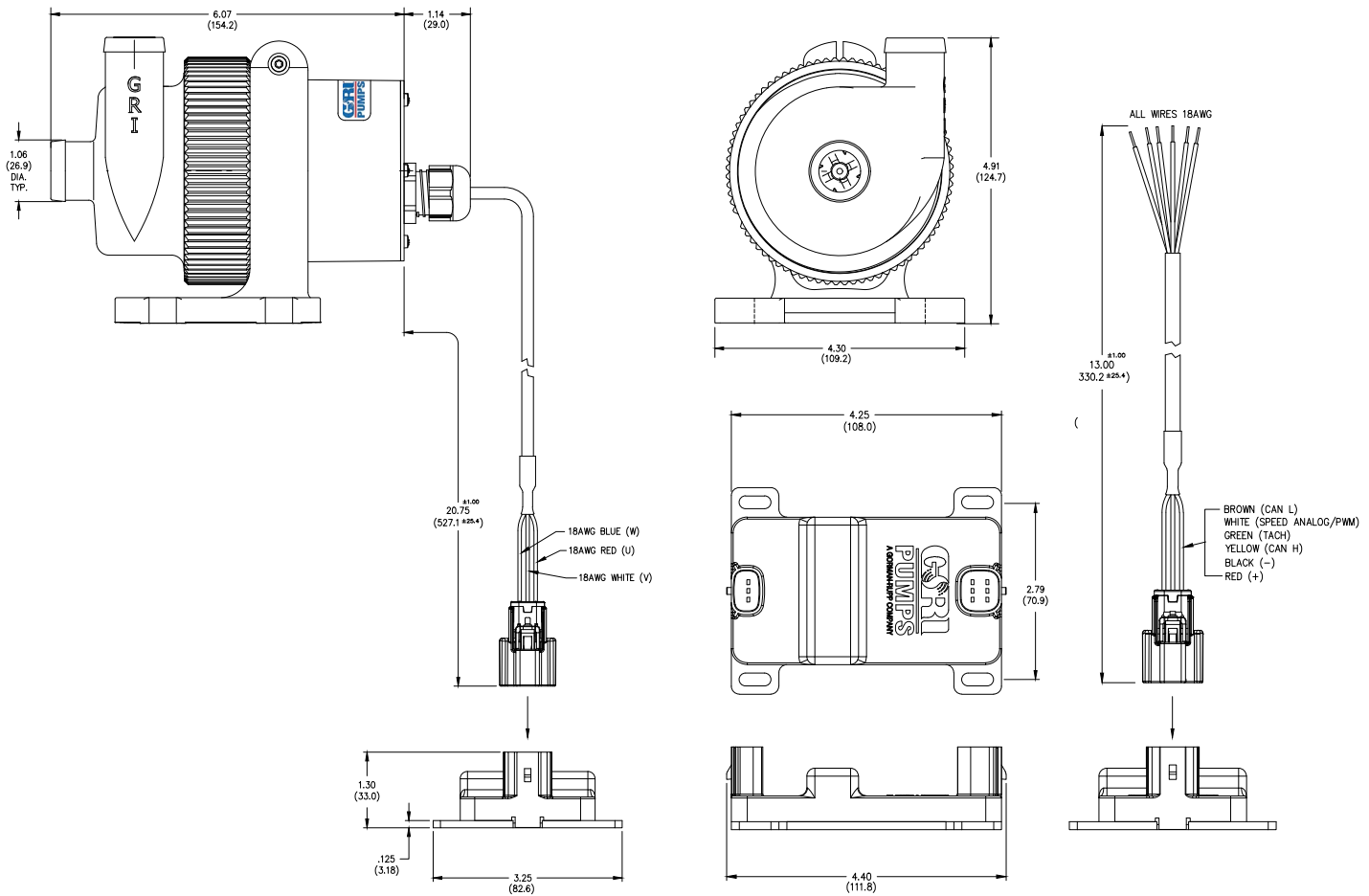

INTG6 Series Typical Dimensional Drawing.
OEM options are available. Please contact GRI to discuss.

Integrity Series Pumps are designed and manufactured specifically for OEM customization. If you don't immediately find a pump that meets your exact requirements, our dedicated Pump Team is ready to work with you in developing a solution specific to your application.

Model (O-RING)	Voltage (VDC)	Speed Control	Lead Wires	Max Flow GPM (LPM)	Max Head Ft. (PSI) (m)	Connections Inlet/Outlet (Inches)
INTG6-244 (EPDM)	12-24 Published performance based on 24v	Analog (0-5v Nominal) Digital (PWM) optional	4 wires (+), (-), Speed Control, Tach	12.00 (45.4)	59.00 (25.6) (18.0)	1" MHB
INTG6-484 (EPDM)	48	Analog (0-5v Nominal) Digital (PWM) optional	4 wires (+), (-), Speed Control, Tach	15.00 (56.8)	70.00 (30.3) (21.3)	1" MHB

Connectors: MHB = Male Hose Barb | **O-Ring Material:** EPDM = Ethylene Propylene Diene Monomer, FKM = Fluoroelastomer (Available on request)