



**!! PLEASE READ in order to maximize the efficiency and life of your GRI pump !!**

The following describes installation requirements and the possible damage which could result from failure to follow these requirements.

**PRIOR TO STARTUP:**

**Connecting Power:** Prior to connecting power, refer to the Electrical Specifications page for important electrical details and wiring diagram. Do not power on the pump without connection to a fluid supply and with fluid contained within the pump's cavity.

**DO NOT RUN DRY:** Never operate the pump without fluid in the pump's cavity. Running the pump dry will destroy the pump.

**Flooded Suction:** It is important that the pump's cavity be filled with fluid prior to startup and during pump operation. To accomplish this, the pump must be positioned so that the fluid supply is above the pump's suction port. This is known as Flooded Suction. Operating the pump without an adequate supply of fluid and/or dry running the pump will dramatically decrease the life of or destroy the pump.

**Supply line:** It is recommended that at least 6.0" (152.4 mm) of straight supply line is connected to the suction port of the pump prior to any turns, angles, or elbows in the plumbing. Not having an efficient length of straight supply line may cause restricted flow, starved suction, and cavitation which will dramatically decrease the life of the pump.

**Flexible or weak walled tubing** should be avoided. Flexible and weak walled tubing may collapse due to the suction force of the pump. Tubing collapse will result in restricted or zero fluid to the pump. Operating the pump without an adequate supply of fluid and/or dry running the pump will dramatically decrease the life of or destroy the pump.

**Pump Positioning:** It is recommended that the pump's suction port be positioned in a horizontal or facing up position. Installing the pump with the suction port facing down is not recommended. Operating the pump with the suction port facing down can cause overworking of the pump due to an inadequate supply of fluid (starved suction).

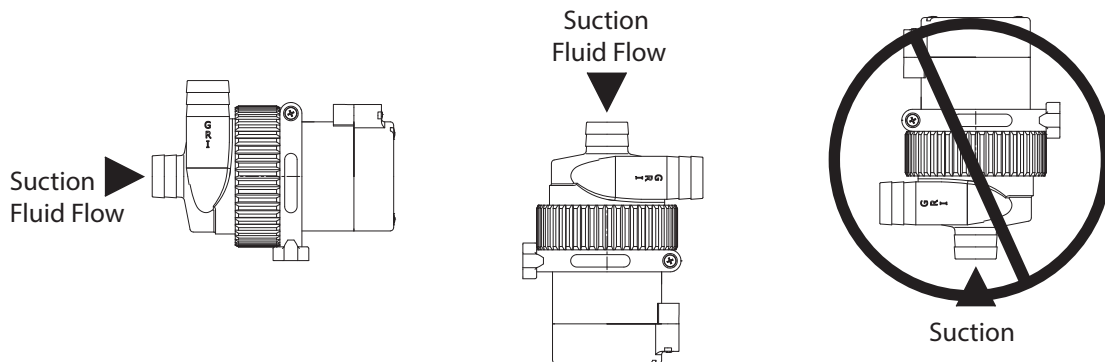

**Pump Body Rotation:** It is highly recommended to not loosen and/or turn/reposition the pump body. Doing so can cause the pump to leak. Special setup and procedures are used in GRI's manufacturing process to attach and position the pump body. Per OEM request, GRI can turn/reposition the pump body prior to shipping. Contact your GRI representative for more information.

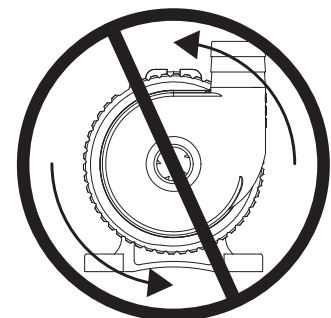

**Contact your GRI representative with questions regarding this information sheet.**